



Insertion Losses of Fiber Optical Connectors

Martin Strasser, Fiber Optics, HUBER+SUHNER AG, Switzerland

HUBER+SUHNER – Excellence in Connectivity Solutions

H+S Technical Series

Table of contents

1	Origins of Insertion Losses of Optical Connectors	3
2	Specification of Insertion Losses	4
3	Measurement of Insertion Losses	5
3.1	Origins of Measurement Errors	6
3.2	Influence of Measurement Errors	7
3.3	Influence of Reference Plug	8
3.4	Quality Assurance at HUBER+SUHNER AG	9
4	Reference Power Measurement	10
4.1	IEC 61300-3-4 Method B	10
4.2	IEC 61300-3-4 Method C	11
5	Optical Time-Domain Reflectometry (OTDR)	12
5.1	Bidirectional OTDR Measurement	12
5.2	Accuracy of OTDR Measurement	13
5.3	Unidirectional Multimode Measurement	14
6	Recommendations at Increased Losses	15

1 Origins of Insertion Losses of Optical Connectors

Fiber-optic connections usually consist of two connectors which are plugged in an adaptor. The major part of the connector is the ferrule in which the optical fiber is glued. Two ferrules are aligned in a so-called sleeve which is part of the adaptor. The insertion losses of fiber-optic connections are determined by the following parameters¹ :

- Lateral misalignment of the fiber core
- Angular offset
- Mode-field diameter of the fibers
- Operating wavelength

Practical experience showed that lateral misalignment of the fiber core is by far the most important parameter². The origins of misalignment can be split in two causes. The first cause is the excentricity of the fiber core which means that the core is not exactly positioned at the center of the ferrule. These deviations come from manufacturing tolerances of fibers and ferrules. The second cause are small alignment errors of the ferrules within the sleeve. These errors are consequences of the tolerances of the ferrule diameter and of the sleeve.

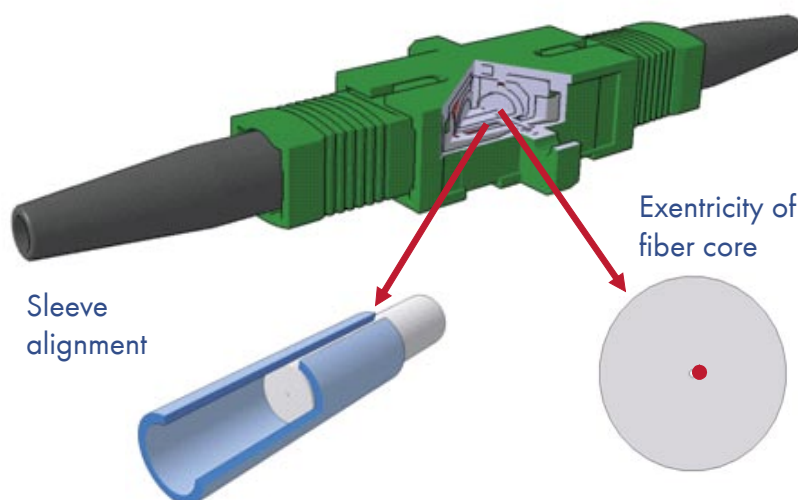

¹D. Marcuse, „Loss Analysis of Single-Mode Fiber Splices“, Bell System Tech. Journal, Vol. 56/6, 1977.

²This is especially valid for fiber-optic connectors with ceramic ferrules.

2 Specification of Insertion Losses

Insertion losses of a class of fiber-optic connections are characterized by loss distributions. The manufacturer specifies the distribution in data sheets of fiber-optic connectors. The distribution of the insertion loss primarily depends on the distribution of the eccentricities and the distribution of the alignment errors of the ferrule within the sleeve. The sum of these distributions results in the distribution of the insertion losses.

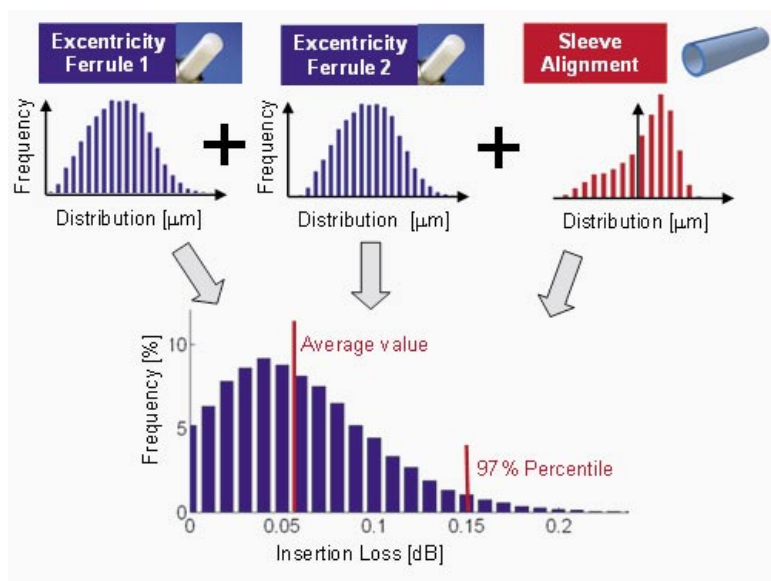

Distribution of eccentricity
+
Distribution of alignment
=
Distribution of losses

The distribution of insertion losses is mainly specified by an average value and a 97% percentile. The 97% percentile means that out of 100 connections (assuming random mating of different connectors and adaptors) 97 connections have insertion losses smaller than the percentile value. The remaining three connections have losses larger than the percentile value.

For instance, the distribution of the 0.1 dB connection class of HUBER+SUHNER AG has a specified average value of 0.06 dB and a 97% percentile of 0.15 dB.

Average value and 97% percentile specify the performance of the connection class

0.1 dB connection class: 97% of IL values are smaller than 0.15 dB



In general, for all classes of connectors, the insertion losses of three percent of all connections can exceed the 97% percentile. These connections are fully within the specifications and are no quality defects. A single measurement is not significant for the performance of a connection class.

Single measurements have no significance

HUBER+SUHNER AG guarantee for all delivered connectors and adaptors (out of a performance class) the specified distribution of the insertion losses. In case of external quality inspection, the customer has to measure the loss distribution of a sufficiently large quantity of connectors and adaptors (!) out of the same performance class. Only deviations of the loss distribution indicate defective quality.

Loss distribution specifies the performance of a connection class.

3 Measurement of Insertion Losses

The measurement of insertion losses has to be performed carefully since various sources of statistic and deterministic errors can deteriorate the measurement result.

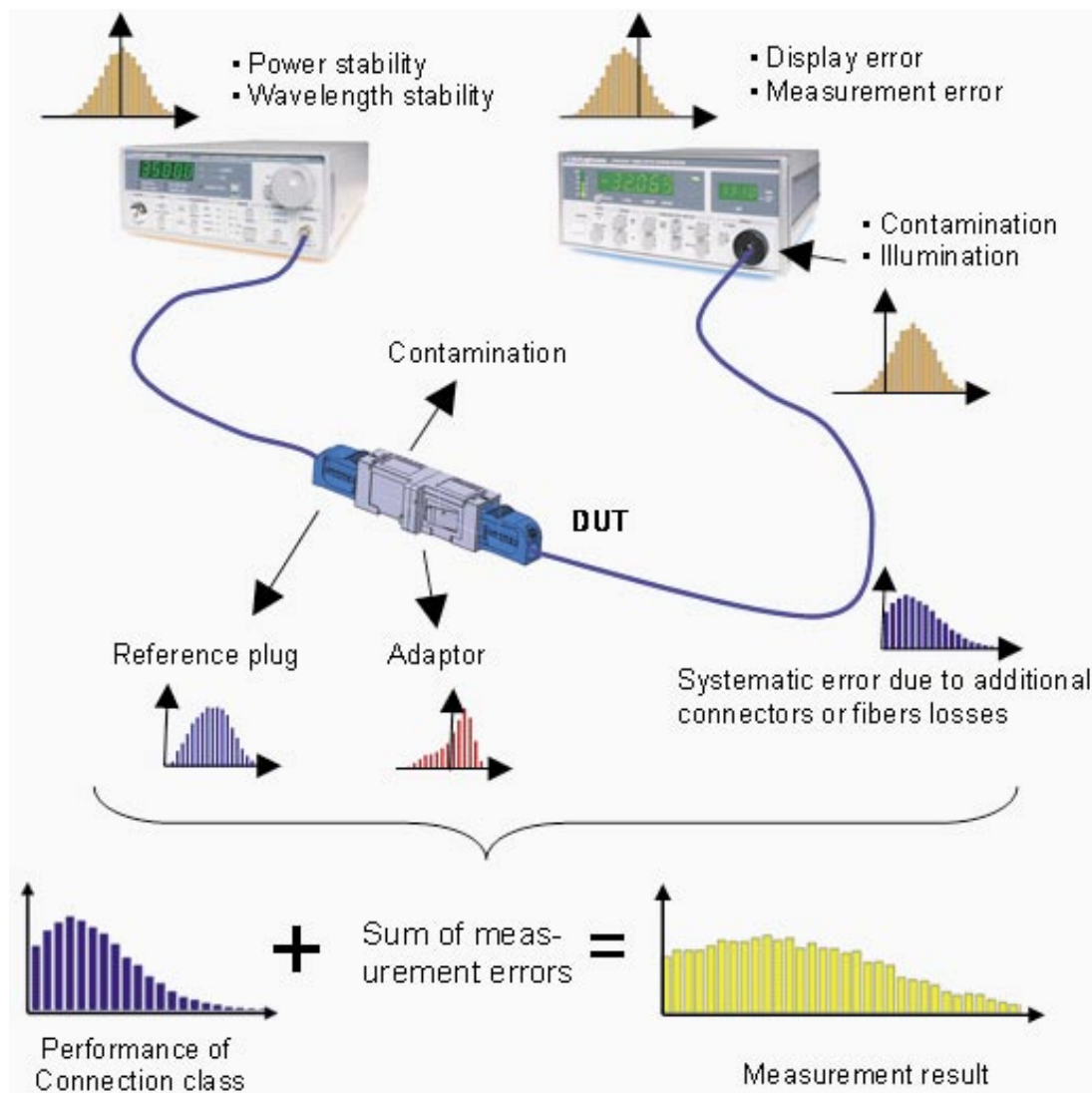

Origins of measurement error

Nominal value
 +
 Measurement error
 =
 Measurement result



Note that an insertion loss can not be assigned to a single connector. It is only possible to measure the insertion loss of a connection consisting of two connectors and one adaptor.

3.1 Origins of Measurement Errors

In practice a large variety of measurement errors occur. By careful implementation of the measurement many of these errors can be avoided, however, some errors can not be prevented. Even under highest accurateness, the measurement is influenced by minimum errors of ± 0.1 dB (3σ). In the following, the different sources of errors are listed:

Connection

- Usage of deficient connectors as reference connectors
- Usage of deficient adaptors
- Contamination of the fiber end-faces
- Contamination of the inner surface of the sleeve or of the outer surface of the ferrule.
- Scratches on the end-face

Light source

- Power stability of the source
- Wavelength stability of the source
- Optical launch conditions for multimode measurements

Power meter

- Accuracy of measurement and display accuracy
- Contamination of connector or sensor
- Illumination of the measurement sensor (photo diode)
- Influence of temperature
- Influence of polarization

Cable

- Losses in measuring line (relevant at long distances, e.g. 0.3dB loss/km)
- Minimum bending radius

Measurement of power reference

- Stability of measurement setup (influence of temperature, etc)
- Systematic error caused by additional connection within measuring line (ΔIL 0.1 dB)

Method of measurement

- Power measurement with reference IEC 61300-3-4 method B → Most accurate method since single connection can be measured.
- Power measurement with reference IEC 61300-3-4 method C → Systematic error caused by additional connection within measuring line.
- OTDR measurement → for obtaining reliable measurement results a careful bidirectional measurement is essential. Possible sources of errors are manifold (cf. 5).

3.2 Influence of Measurement Errors

The measurement of insertion losses can be deteriorated by various errors (cf. 3.1). The sum of the negative influences can only be minimized by careful implementation of the measurement within a controlled environment and by using calibrated precision instruments. However, even under best conditions, it is difficult to achieve an accuracy better than ± 0.1 dB.

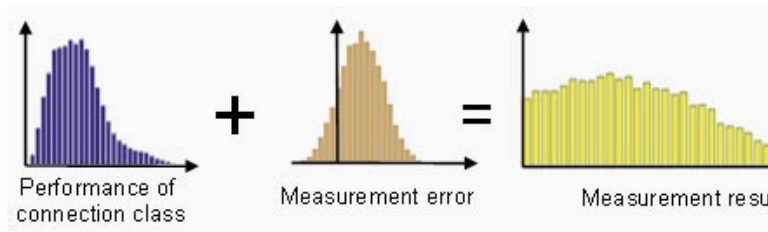

This means that a loss of nominal 0.25dB can yield measurement results between 0.15dB and 0.35dB. Under a less controlled environment or with less precise measurement methods (e.g. OTDR), the spread can be considerably larger.

When measuring losses of the 0.1dB connection class, the measurement error is equally large as the value to be measured. A precise measurement is hardly possible any more. If the customer performs a quality inspection of the 0.1dB class, the loss distribution has to be measured. However, as a result of the measurement error the loss distribution may be such strongly biased that the measurement has no significance any more. In that case, a larger amount of single measurement results yield values above 0.1dB although the products themselves fulfill the specifications.

In practice, measurement accuracy is max. ± 0.1 dB.

Loss distribution is affected.

0.1dB connection class:
Measurement error is equally large as value to be measured.

3.3 Influence of Reference Plug

The excentricity of the fiber core within the ferrule varies statistically. If a connector is randomly chosen out of a multitude, in the worst case, the excentricity can be almost out of specifications. When using such a connector within an adaptor, the connection suffers from increased losses.

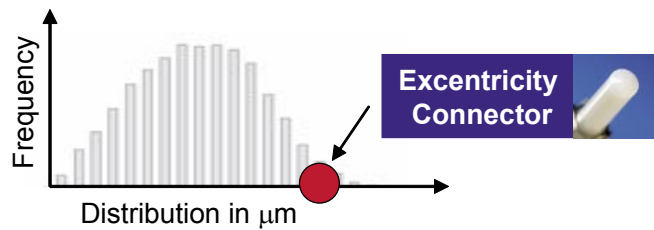

Example of an extreme case of ferrule excentricity

If such an unfavorable connector is used as reference plug within a measurement, the measurement yields increased losses even though the second connector (to be measured) is within specifications. The result is falsified by the reference plug. Note, not only single measurement results are falsified but the entire loss distribution.

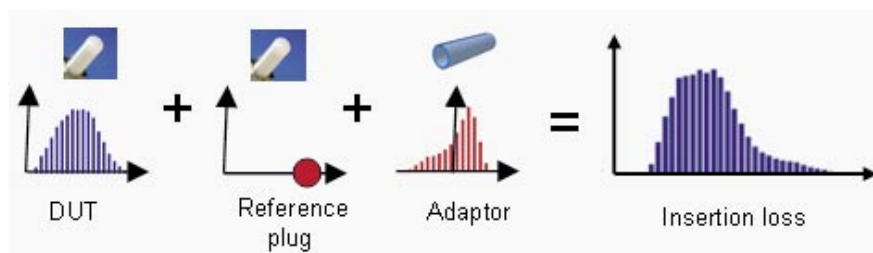

Reference plugs can deteriorate the measurements.

For absolutely correct determination of the performance of a connection class, each measurement needs to be performed with different reference plugs. Only under such circumstances the reference plug features the nominal variance which is required for obtaining the correct loss distribution. However, this approach is not practicable by what the reference plug needs to be selected carefully. An unfavorable as well as a best choice of a reference plug affect adversely the measurements. The basic problem is that a single connector can never be characterized but only a pair of connectors within an adaptor. Additionally, a single connection can never characterize the performance of a class of connectors. Only the loss distribution of a variety of connectors is significant.

Proper choice of the reference plug is important for the quality of the measurement



A contaminated or scratched reference plug can deteriorate the measurement result considerably. The same is valid for adaptors with worn or contaminated sleeves.

3.4 Quality Assurance at HUBER+SUHNER AG

How can HUBER+SUHNER AG guarantee the quality?

The optical performance, i.e. the insertion loss, of each single connector is measured in production before delivery to the customer. A 100% quality inspection is performed. The end-control measurement is subject to an error of maximum ± 0.1 dB.

Huber+Suhner AG perform 100% end-quality inspection.

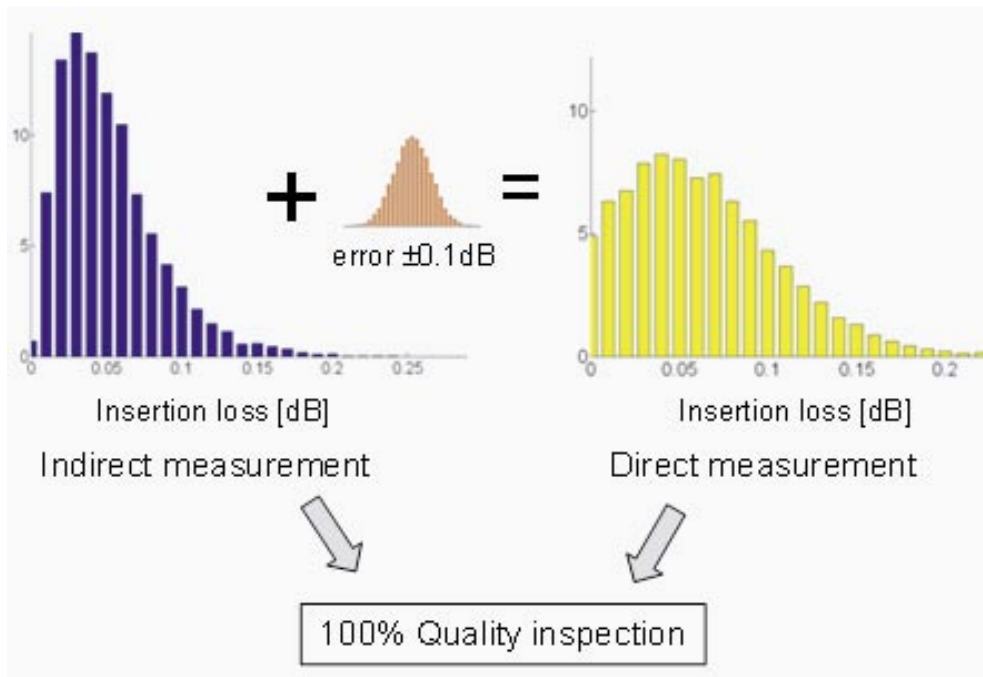

For fully ensuring the specified quality and performance, all fibers, ferrules, and sleeves undergo a detailed receiving inspection. By means of mathematical models, the insertion losses can be determined accurately from the geometrical deviations of the components. This means the insertion loss is additionally measured by this indirect method. The comparison of the indirectly measured losses with the direct results guarantees the reliable and consistent quality of the products.

Manufacturer guarantees performance by direct and indirect measurement.

HUBER+SUHNER AG are a high-quality manufacturer of optical connectivity solutions. The company ever tries the best to deliver the highest quality for the satisfaction of the customer.

³Die Messgenauigkeit von ± 0.1 dB (3σ -Wert) unter Produktionsbedingungen wird durch Vergleichsmessungen durch akkreditierte Schweizer Test und Kalibrationslabors sichergestellt.

4 Reference Power Measurement

The most reliable method for determining the insertion loss is the comparison of a power reference P_0 to a measured power P_1 ,

$$\text{Insertion loss IL [dB]} = -10 \log P_1 / P_0.$$

The IEC norm 61300-3-4 describes in detail the correct implementation of the measurement. Amongst others, (1) a correct illumination of the fiber, (2) the usage of calibrated high-precision instruments, and (3) a one-hour thermal stabilization of the measurement setup are stringent requirements demanded by IEC.

Correct implementation of the measurement according to IEC.

4.1 IEC 61300-3-4 Methode B

A source (S) launches light into the fibers and mode filters (mf) guarantee the correct launch conditions. For measuring of the reference power P_0 , the reference plug (RP) is directly attached to the power meter⁴ (D). In a next step, the connector to be measured (DUT) is connected to the reference plug and power P_1 is measured. Method B measures the insertion loss between the reference plug (RP) and the test connector (DUT).

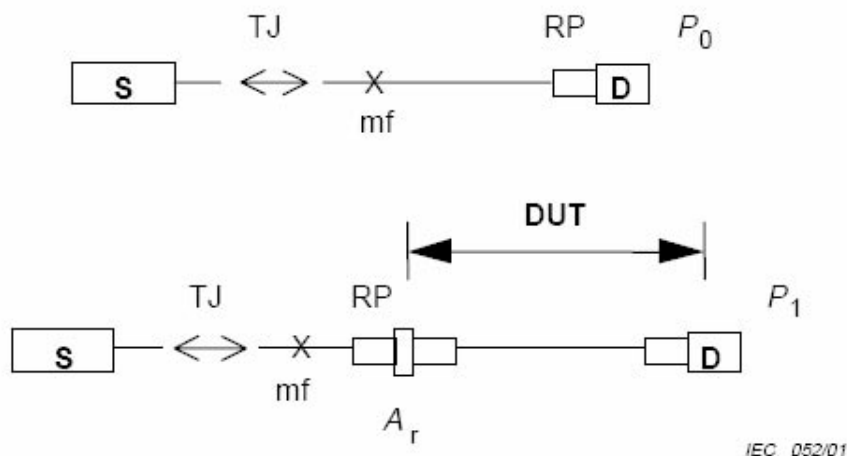

Method B of IEC norm 61300-3-4 is the most accurate and most reliable measurement.

This method yields the most accurate and reliable measurement results of insertion losses of a single connection. In case that other measurement methods (e.g. OTDR) result in differing losses, the more reliable results of method B have to be preferred⁵.

⁴ The connector attached to the power meter (D) causes no additional losses provided that the power sensor is sufficiently large to detect the entire light.

⁵ Presumed that all measurements are performed with the same accurateness.

4.2 IEC 61300-3-4 Methode C

In many cases, the cable to be measured can not be attached directly to the power meter (D). In this case, measurement method C has to be used. The reference setup for measuring P_0 includes a test cable with an additional connection. Subsequently, the cable to be measured (DUT) is inserted between the reference plugs (RP) to measure the power P_1 . Note that the losses of two connections are measured simultaneously. The corresponding losses of the individual connectors can not be extracted. To obtain more accurate results the measured loss can be corrected by the (assumed) average value of the second connection. However, the level of inaccuracy is significantly increased compared to method B.

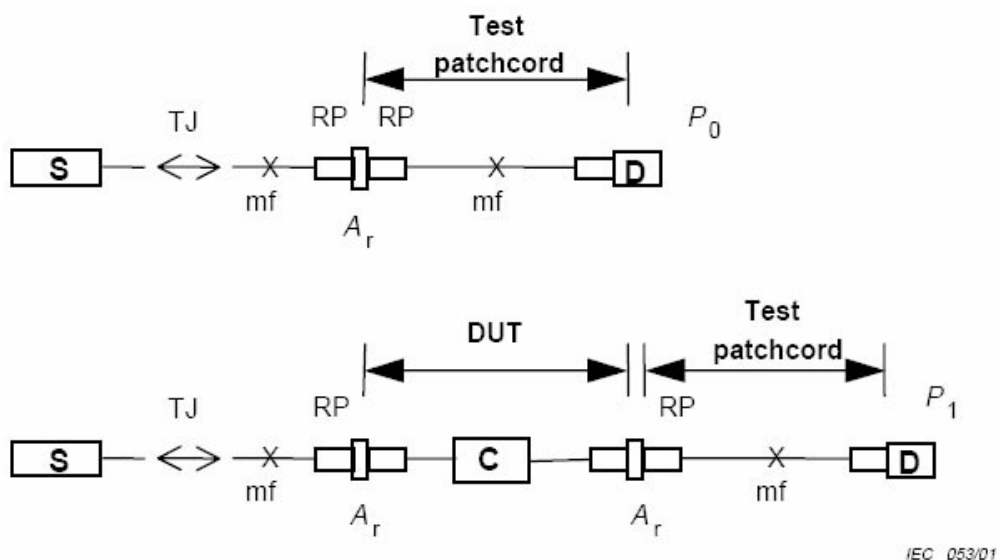

Method C of IEC norm 61300-3-4 measures two connections simultaneously.



This measurement is not an adequate method to accurately determine the insertion loss of a single connection. Nevertheless, if method C is used, the measurement error is increased by the insertion loss (>0.1 dB) of the second connection.

This method is mainly used to inspect the losses of pre-installed cables. In that case, an additional source of error is the physically separated measurement of the reference and of the DUT (influence of temperature, thermal stabilization, etc.).

5 Optical Time-Domain Reflectometry (OTDR)

Optical Time-Domain Reflectometry performs not a direct measurement of insertion losses but is an estimation of the losses based on the back-scattered light⁶. This method yields less accurate and less reliable results as compared to power meter measurement.

A prerequisite for performing an OTDR estimate of losses is that exactly the same optical fiber is deployed in the entire line. As compared to practice, it is often the case that different types of optical fibers are installed. Already marginal differences in the effective refractive indices or of the core diameter can result in considerable errors (>0.5dB) at unidirectional measurements. Hence, single-ended OTDR tests yields unusable results⁷. Renowned manufacturers of OTDR equipment (e.g., EXFO⁸) emphasize the importance of bidirectional measurements for singlemode fibers.

OTDR is not a direct measurement but an estimation.

Single-ended tests yield wrong results.



Although fibers delivered by different manufacturers or by different shipments are fully within specifications, minor tolerances and deviations always exist. These differences are sufficient to cause significant errors at single-ended OTDR tests.

5.1 Bidirectional OTDR Measurement

The IEC Norm 61300-3-4 and manufacturers of OTDR equipment stringently demand a bidirectional measurement for singlemode fibers. Additional fiber sections L1 and L2 at sufficient length have to be used in order to overcome the attenuation dead zone of the instrument. A correct implementation of the bidirectional measurement yields reliable results. A unidirectional is an incorrect method generating unacceptable errors.

IEC and renowned manufacturers stringently require bidirectional OTDR measurements for singlemode fibers.

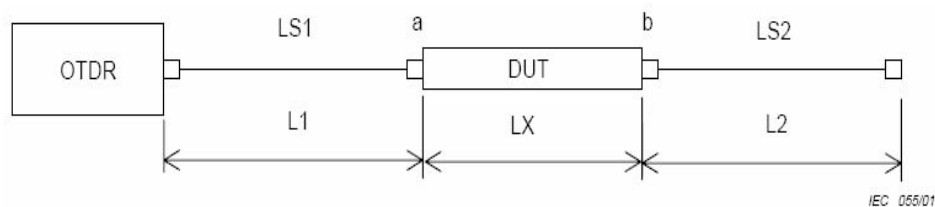

In practice, unidirectional OTDR measurements are sometimes used due to cost saving or lack of expertise. However, single-ended tests are only able to detect sizeable errors within the network but can not be used for quality inspection of connectors or similar.

⁶The so-called Rayleigh scattering is the origin of fiber attenuation

⁷D. Eberlein, Lichtwellenleiter-Technik, Espert Verlag, 5. Auflage, 2003.

⁸C. Hamel, Bidirectional OTDR Testing: Multimode vs. Singlemode Fibers, EXFO Application Note 043.

5.2 Accuracy of OTDR Measurement

The accuracy of the measurement depends on the so-called signal-to-noise ratio (SNR), which is influenced by the setting parameters of the instrument. A sub-optimum setting of the parameters results in poor SNR and large measurement errors⁹. Since the measurement is not always performed by qualified personnel, modern instruments support choosing the optimum settings of parameters.

- **Pulse Width:** Short pulses increase the spatial resolution and can detect more accurately events. In contrast, the poorer SNR of short pulses decreases the accuracy.
- **Averaging:** Averaging of consecutive measurements increases the SNR. Hence, for maximum accuracy as many measurements as possible should be averaged. For optimum results, EXFO recommend an average time of three minutes at each measurement¹⁰.
- **Bandwidth and Sampling Rate:** These parameters, which vary from instrument to instrument, determine to a large extent the quality of the measurement. Hand-held instruments feature usually inferior accuracies than lab instruments.
- **Linearity:** Modern instruments have a specified linearity of 0.05dB/dB. This means that a nominal attenuation of 1dB can be measured with an accuracy of 0.05dB. The displayed valued may vary between 0.95dB and 1.05dB.

OTDR is not a direct measurement of the insertion loss but an estimation based on statistics and mathematical models.



OTDR instruments may display the measurement results with an accuracy of 0.01dB. Note, the display accuracy has no relation to the measurement accuracy which is the crucial factor.

⁹ C. Hamel, J. Barnard, Optimizing OTDR Measurement Parameters, EXFO Application Note 076.

¹⁰ P. Talbot, C. Hamel, M.-C. Michel, OTDR and OLTS: Two different Tools for Specific Needs, EXFO Application Note 026.

The accuracy of an OTDR measurement depends on the instrument settings.

5.3 Unidirectional Multimode Measurement

An OTDR measurement of multimode fibers relies on different principles than a measurement of singlemode fibers. The measurement strongly depends on the distribution of the optical modes within the fiber. For that reason the accuracy of the measurement is lower and the reproducibility worse. In contrast to singlemode, unequal fibers have only a marginal impact on the result. Additionally, multimode losses depend on the direction of light propagation, hence the benefits of bidirectional measurements are reduced. OTDR measurements for multimode fibers are performed unidirectional.

Only for multimode fibers a unidirectional measurement is correct.

6 Recommendations at Increased Losses

At the technical approval of installed networks or at customer quality inspection the insertion losses of the fiber optic connection (cable and connectors) are verified. At the occurrence of increased losses the following procedure is recommended.

The technician who performed the measurements needs to find out the origins of the increased losses. The following questions needs to be answered.

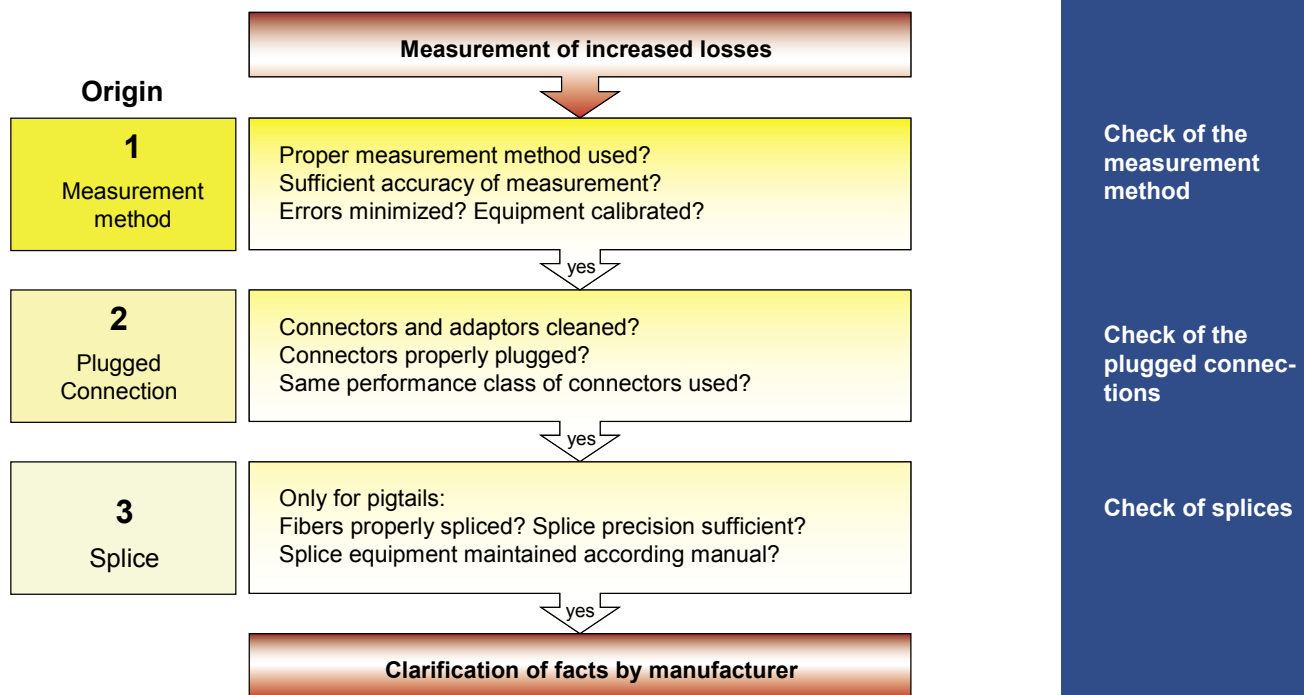

An essential requirement is the application of the proper measurement method and the usage of accurate measurement equipment. Only if a sufficient measurement reliability and accuracy can be assured by the technician, this origin of errors can be excluded.

A second step needs to check whether the fiber optic connection is properly installed. All plugged connectors and adaptors needs to be clean, the minimum bending radii are maintained, and no cable damages exist.

Thirdly, if pigtails are used, the quality of all splices needs to be assured. In case of doubt, the spliced have to be renewed.

If all previous reasons for increased losses can explicitly be excluded, it is recommended to contact the manufacturer for clarification.



HUBER+SUHNER AG
Fiber Optics
9100 Herisau, Switzerland
Phone +41 (0)71 353 41 11
Fax +41 (0)71 353 46 47
www.hubersuhner.com

HUBER+SUHNER – Excellence in Connectivity Solutions